

# TOF Sensor TOF-2D-EA

Operating and Instruction Manual

EN

Measuring 3-D TOF Sensor for  
Presence and Motion Detection

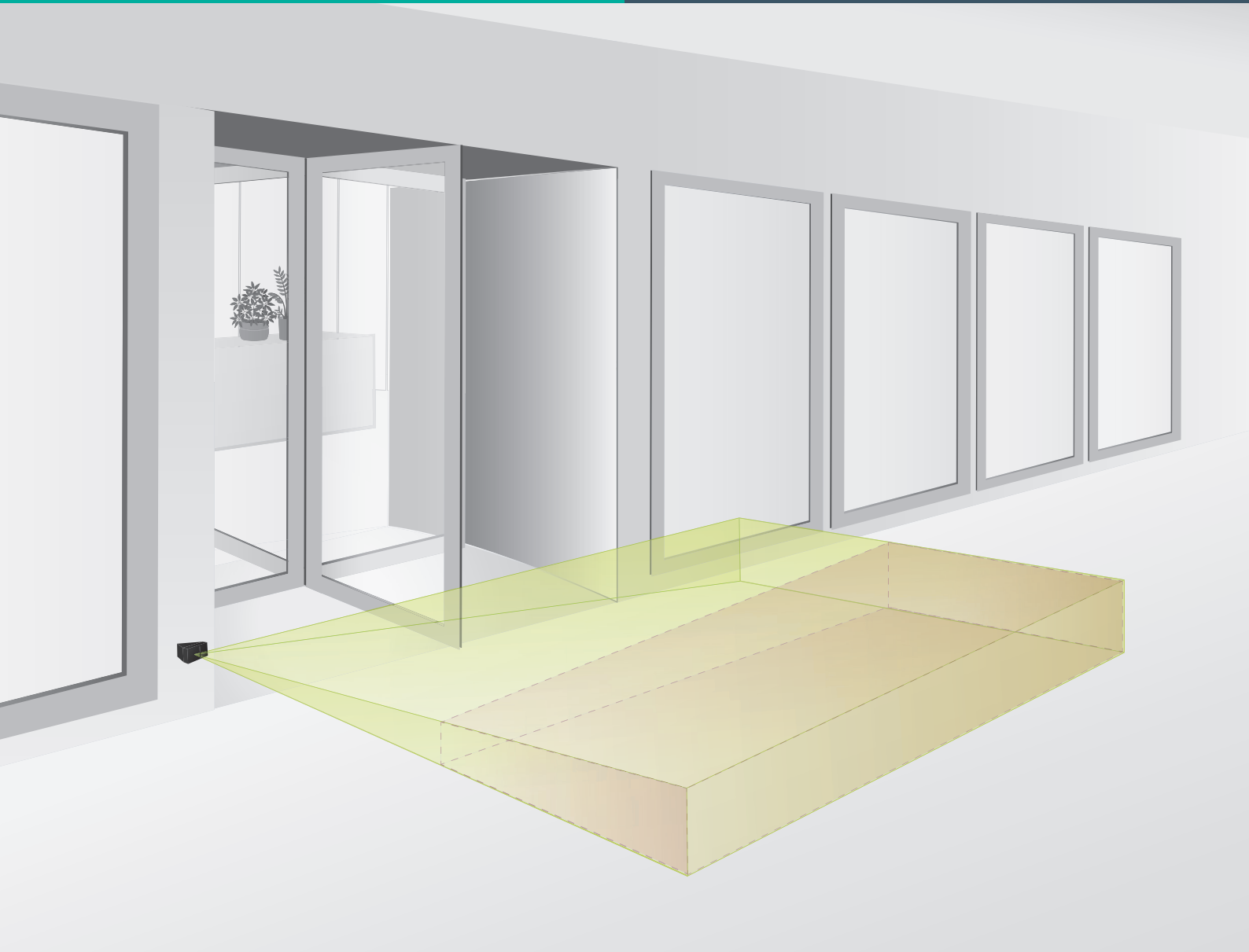

# Operating and Instruction Manual

EN

Order designation: Measuring 3-D TOF sensor for presence and motion detection

Art.No. 10001857

## Table of content

<b>1. Introduction</b>	<b>3</b>
1.1 About this manual	3
1.2 Safety information – IMPORTANT! READ BEFORE INSTALLATION!	3
<b>1.2.1 To ensure safe conditions</b>	<b>3</b>
1.2.2 Non-intended use	4
1.3 Symbols, safety messages	4
1.3.1 Safety messages categories	4
1.3.2 Informative notes	5
1.4 Declaration of conformity	5
<b>2. Scope of delivery and device description</b>	<b>5</b>
2.1 Delivery package	5
2.2 Device description	5
2.3 Dimensions	7
2.3.1 Sensor	7
2.3.2 Mounting brackets	7
2.4 Type description	7
2.5 Features of the TOF-2D-EA	7
2.6 Application examples	7
<b>3. Configuration</b>	<b>8</b>
3.1 Type of threshold setting	8
3.1.1 Threshold setting via potentiometer	8
<b>4. Installation</b>	<b>9</b>
<b>5. Input / Output description and electrical connection</b>	<b>9</b>
<b>6. Start-up</b>	<b>9</b>
<b>7. Timing diagram</b>	<b>10</b>
<b>8. LED signals</b>	<b>10</b>
<b>9. Cross-traffic</b>	<b>11</b>
<b>10. Blanking</b>	<b>12</b>
<b>11. Trouble shooting</b>	<b>13</b>
<b>12. Maintenance</b>	<b>13</b>
<b>13. ESD-Safety</b>	<b>13</b>
<b>14. Decommissioning</b>	<b>13</b>
<b>15. Disposal</b>	<b>14</b>

### Sensotek GmbH

Specialist for entrance automation within the Pepperl+Fuchs Group

Stuttgarter Str. 119, 73061 Ebersbach (Fils), Germany

Tel.: +49 7163 93926-0, Fax: +49 7163 93926-10, info@uk.sensotek.com

# 1. Introduction

## 1.1 About this manual

This document contains information you need to use your product in the applicable phases of the product life cycle. This may include

- Product identification
- Delivery, transport, and storage
- Assembly and installation
- Commissioning and operation
- Maintenance and repair
- Troubleshooting
- Disassembly
- Disposal

The documentation consists of the following parts:

- Operating and installation instructions (= this document)
- Data sheet

In addition, the documentation may consist of the following parts, if applicable::

- Certificate of conformity
- Certificates

## 1.2 Safety information – IMPORTANT! READ BEFORE INSTALLATION!

The TOF-2D-EA was developed and manufactured using state-of-the-art systems and technologies. However, injury and damage to the sensor can still occur.

### 1.2.1 To ensure safe conditions

- Read all enclosed instructions and information.
- Follow the instructions given in this manual carefully.
- Observe all warnings included in the documentation and attached to the sensor.
- Do not use the sensor if it is damaged in any way.
- Keep the instruction manual on site.

The TOF-2D-EA should only be installed by authorized and fully trained personnel! The installer or system integrator is fully responsible for the safe integration of the sensor. It is the sole responsibility of the planner and/or installer and/or buyer to ensure that this product is used according to all applicable standards, laws and regulations in order to ensure safe operation of the whole application.

Any alterations to the device by the buyer, installer or user may result in unsafe operating conditions. Sensotek GmbH is not responsible for any liability or warranty claim that results from such manipulation.

Failure to follow instructions given in this manual and/or other documents related to the TOF-2D-EA may cause customer complaints, serious call backs, damage, injury or death.

### 1.2.2 Non-intended use

TOF-2D-EA **must not be** used for:

- Protection of dangerous machine
- Equipment in explosive atmospheres
- Equipment in radioactive environments



Use only specific and approved safety devices for such applications, otherwise serious injury or death or damage to property may occur!

## 1.3 Symbols, safety messages

Symbol	Meaning
■	Single instruction or measures in no particular order
1. 2. 3.	Sequenced instructions
■	List, in no order of importance
→	Reference to a chapter, illustration or table within this document
Important	Important information for the correct use of the sensor

This document contains symbols to indicate warnings and informativenotes.

### 1.3.1 Safety messages categories

Warning notices are always provided when your actions could pose a hazard.

It is essential that you observe these warning notices for your own personal safety and to avoid damage to property.

Depending on the level of risk, the warning notices are displayed in descending order as follows:



#### **Danger!**

This symbol warns you of an imminent danger.  
Failure to observe this warning may result in personal injury or death.



#### **Warning!**

This symbol warns you of a possible malfunction or danger.  
Failure to observe this warning may result in personal injury or serious damage to property.



#### **Caution!**

This symbol warns you of a possible malfunction.  
Failure to observe this warning may result in the product or connected systems and equipment malfunctioning or failing completely.

### 1.3.2 Informative notes



**Notes:**

This symbol indicates important information.

## 1.4 Declaration of conformity

### EC-Declaration of conformity – Extract

The TOF-2D-EA product complies with the following directives and harmonized standards:

EU-Richtlinien/EU-Regulation	Normen/Standards
2006/42/EC/ Supply of Machinery (Safety) Regulations 2008	EN 60068-2-6:2008
2014/30/ EU / Electromagnetic Compatibility Regulations 2016	EN 60068-2-27:2009
2014/35/EU / Electrical Equipment (Safety) Regulations 2016	EN 61000-6-2:2005
2011/65/EU / The Restriction of the Use of Certain Hazardous Substances in Electrical and Electronic Equipment Regulations 2012	EN 61000-6-3:2007
	EN 12015:2014
	EN 12016:2013

The full declaration of conformity can be downloaded at [www.sensotek.com](http://www.sensotek.com).

## 2. Scope of delivery and device description

### 2.1 Delivery package

A delivery package contains:

- 1 × TOF-2D-EA sensor with pigtail cable
- 1 × Connection cable (2 m)
- 1 × Installation guide

### 2.2 Device description

The TOF-2D-EA (Entrance Automation) is a compact yet powerful sensor which detects people and objects and reliably triggers an opening signal. The sensor has been specially developed as a door opener for both pedestrian doors and industrial doors. Its TOF technology enables the TOF-2D-EA to operate with all types of backgrounds without any need to recalibrate. Its key advantage is its ability to reliably distinguish between traffic passing by (cross-traffic) and traffic that intends to go through the door. This ability to automatically ignore cross-traffic greatly boosts energy-saving and reduces mechanical stress on the doors caused by unnecessary openings.

## Technical Data

### General data

Eye safety	EN 62471:2008
EMV emission	EN 61000-6-3:2007 EN 12015:2014
EMV Immunity	EN 61000-6-2:2005 EN 12016:2013
Vibration	IEC 60068-2-6:2007
Shock	IEC 60068-2-27:2008
RoHS	2011/65/EU
Certificate	CE

### Optical

Detection area	
- Length	Min. 0 ... 400 mm; Max. 0 ... 2000 mm
- Width	Min. 0 ... 400 mm; Max. 0 ... 2000 mm

### Mechanical

Dimensions (w × h × l)	57 × 34 × 44.5 mm
Housing material	Polycarbonate
Housing color	Black
Enclosure rating	IP65
Temperature range	-20 °C ... +65 °C

### Electrical

Supply voltage $U_{sp}$	24 VDC ±20%
Current consumption at 24 VDC	50 mA (peak max. 0.5 A)
Output	PNP/NPN (push-pull)
Max. response time	
Area without cross-traffic < 1 m	200 ms
Area with cross-traffic > 1 m	400 ms
Min. switching time	200 ms
Power-on time	1 s

### Sensor: Connection cable and electrical connections

Length	0.25 m
Connection	M8, 6-pin
Diameter	Ø 4.2 mm
Material	PVC, black
Plug color	Blue

### Connection cable and electrical connections

Length	2 m (other lengths on request)
Connection	M8, 6-pin
Diameter	Ø 4.2 mm
Material	PVC, black
Plug color	Blue
Wires	AWG26
• brown	$U_{sp}$
• black	Output
• green	Not connected
• blue	GND (0 V)
• white	Not used
• gray	Selectable output logic

### Zulassungen und Zertifikate

CE	may be operated in all countries of the European Community. In other countries, the applicable national regulations must be observed.
----	---

## 2.3 Dimensions

### 2.3.1 Sensor

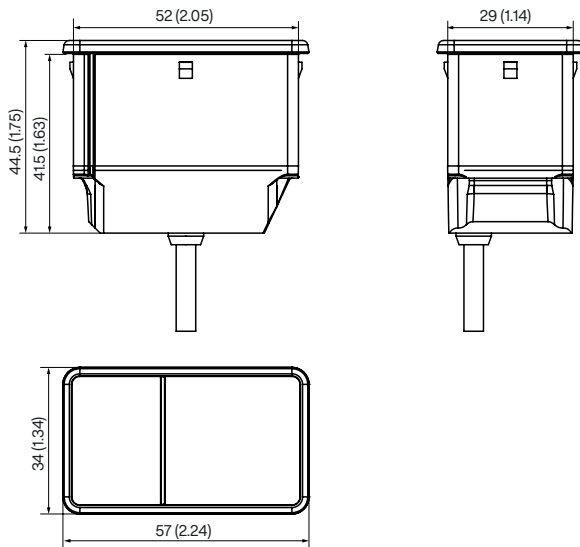

### 2.3.2 Mounting brackets

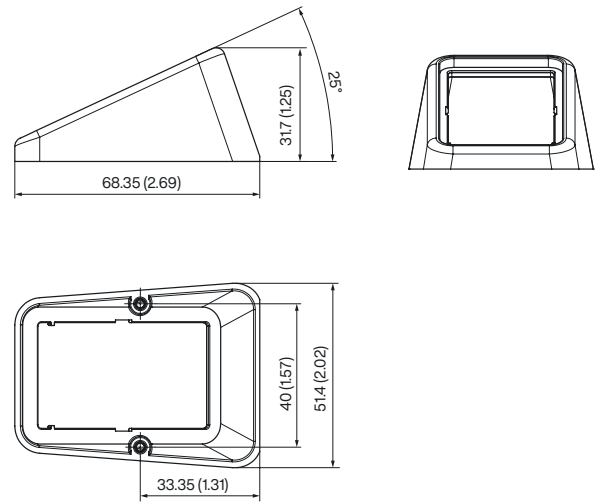

Figure 1: All dimensions in mm (and inches)

## 2.4 Type description

**TOF-2D-EA-N-B:** Potentiometer/Blanking

**TOF-2D-EA-N:** Potentiometer

**TOF-2D-EA-T:** Teach-In

**TOF-2D-EA-T-B:** Teach-In/Blanking

## 2.5 Features of the TOF-2D-EA

- Excellent detection capability, independent of reflectance
- Ignores cross-traffic via intelligent direction recognition
- Individual setting of the detection area
- Detection area operates with all types of background

## 2.6 Application examples

- intelligent door opening with cross traffic suppression

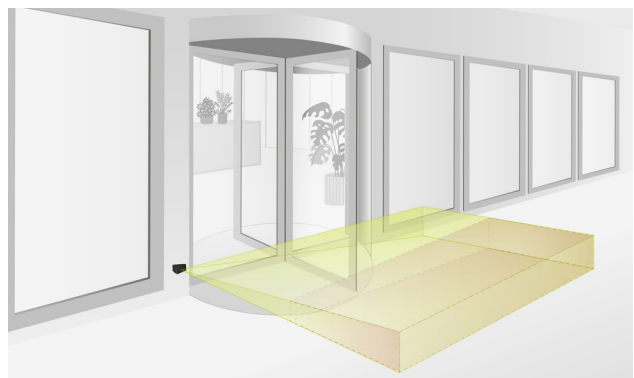

# 3. Configuration

## 3.1 Type of threshold setting

The distance at which the sensor triggers an output is the threshold. The TOF-2D-EA requires a threshold setting for the x-axis as well as the y-axis using potentiometers. A factory setting, as well as a mixture of potentiometer and preset, are also possible on request.



**Notes:** The sensor uses a  $\pm 120$  mm ( $\pm 4.72$  in) hysteresis. The hysteresis is the difference between the switching points changing the status from 'free field' to 'object detected' and back from 'object detected' to 'free field', compared to the nominal limit.

### 3.1.1 Threshold setting via potentiometer

The threshold distance at which the sensor triggers an output is set with a potentiometer for the x-axis and y-axis. This is done using the potentiometer at the back of the sensor. If the sensor points to a background, the distance of the switching threshold to the background is recommended to be set at 150 mm.



**Important:** When mounted horizontally, the cable exit of the sensor in the Figure 3 is always at the bottom.

- The scale is not printed on the sensor. The potentiometer can be adjusted linearly from 0.4 m to 2.0 m; see Figure 3 below.
- Take a small screw driver and turn the potentiometer to the required position.

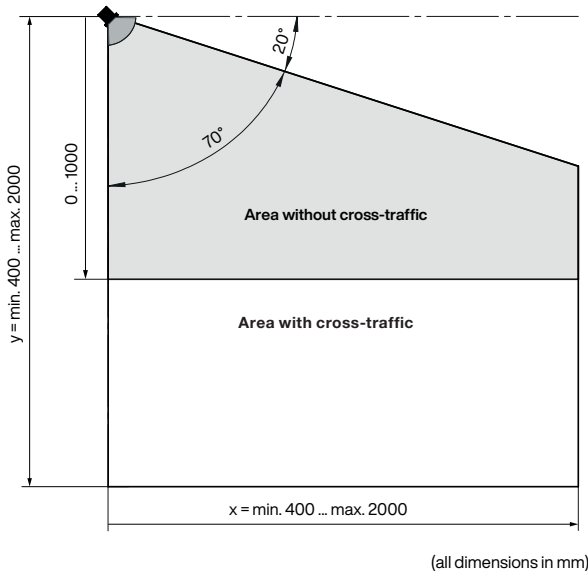

Parameter	Value
Operating range x-axis	Min.: 0 ... 400 mm Max.: 0 ... 2,000 mm
Operating range y-axis	Min.: 0 ... 400 mm Max.: 0 ... 2,000 mm
Aperture angle	70°

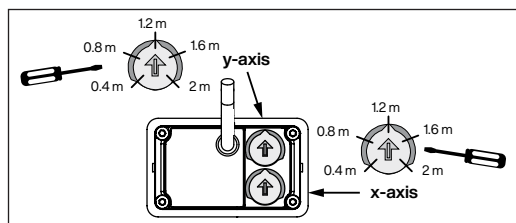

Figure 3: Detection field using potentiometer

## 4. Installation



### Important:

The TOF-2D-EA must be mounted at a minimum 10° mounting angle to the ground.

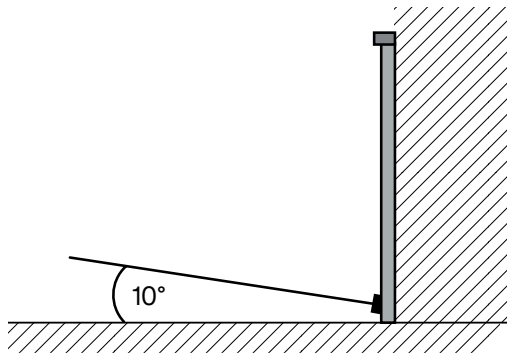

Figure 4: Mounting angle of TOF-2D-EA

## 5. Input / Output description and electrical connection

Generally the TOF-2D-EA has one output that is triggered if the detection field is interrupted. For this purpose, a push-pull output is used. With the logic selector (gray wire, Figure 6), the logic of the output signal can be configured for "HIGH" on object or "LOW" on object operation (Figure 5), according to the controller requirements.

The logic selection is performed during start-up.

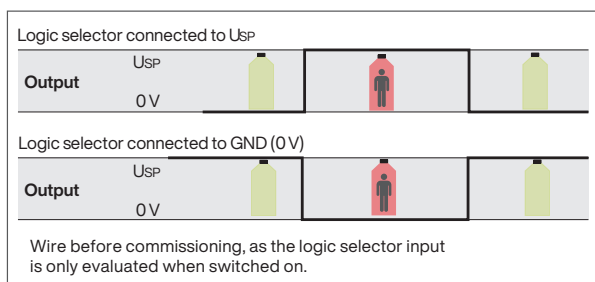

Figure 5: Output (PNP/NPN) logic

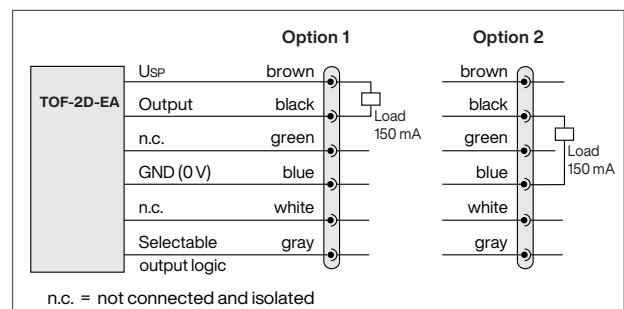

Figure 6: Connection diagram

## 6. Start-up

1. Switch on mains and power up.
2. Check if LED lights up.
3. Check the distance setting and the reaction of the sensor, including the status LED, by placing an object into the detection area at different heights and widths.

# 7. Timing diagram

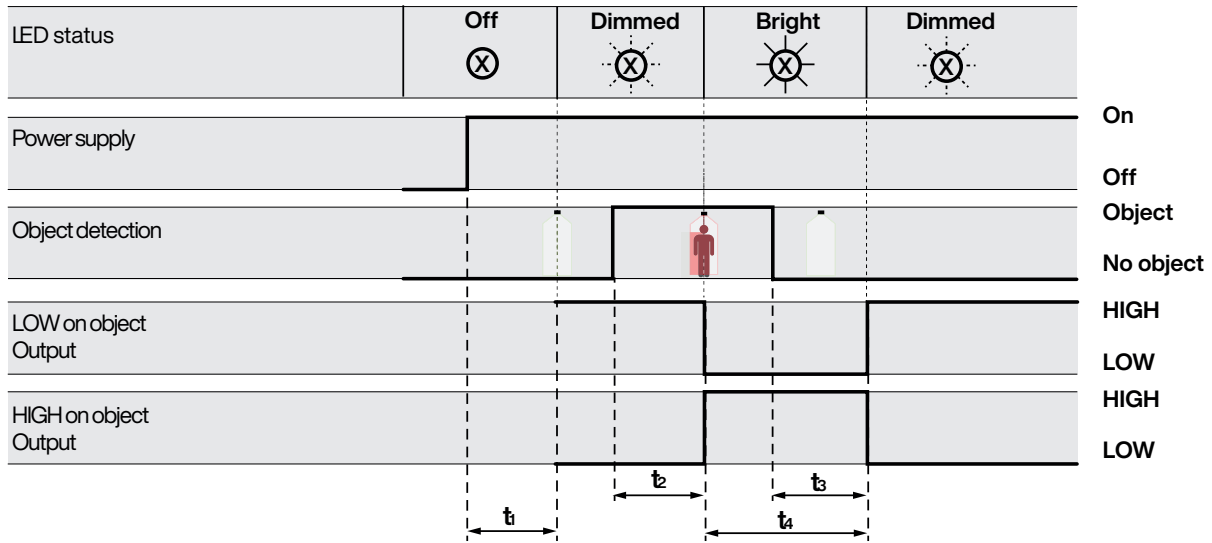

Figure 7: General timing diagram

	Time	Value [ms]
Power-on time	$t_1$	1,000
Max. response time	$t_2$	
• Area without cross-traffic < 1 m		200
• Area with cross-traffic > 1 m		400
Release time	$t_3$	200
Min. switching time	$t_4$	200

Figure 8: General timing table

# 8. LED signals

The red LED provides the sensor's status. The respective LED is dimmed when the power is OK and the detection field is free. The LED glows bright when an object is detected and the respective output triggered. The LED is visible from the front.

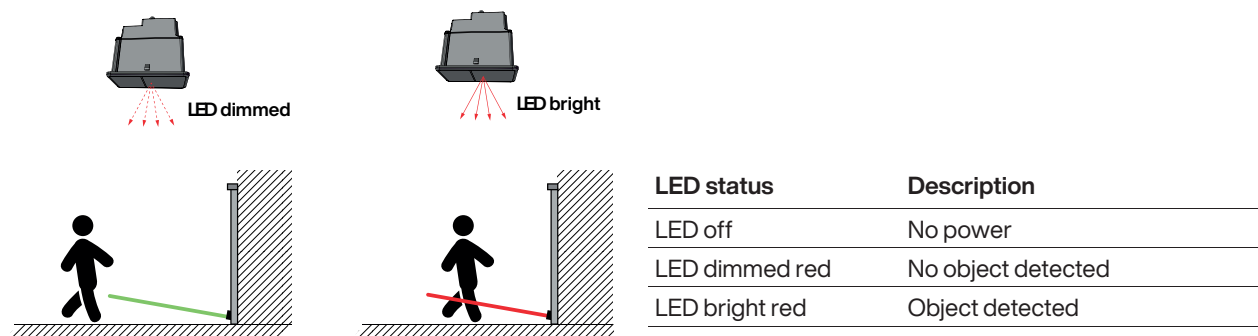

Figure 9: LED indicator

# 9. Cross-traffic

The TOF-2D-EA features a cross traffic detection function. If a person moves towards the door entrance area, the TOF-2D-EA triggers the output. If the person only moves across the door entrance area, the TOF-2D-EA recognizes that the person does not wish to use the door and does not trigger the output.



**Important:**

**The cross-traffic activation zone begins at a 1 meter distance from the sensor.**

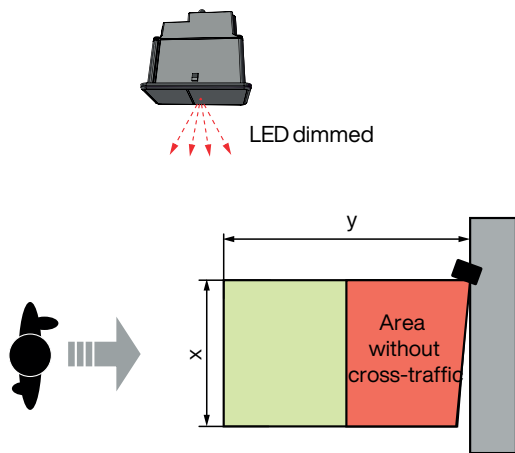

Figure 10: Detection field free; person moves towards the door entrance area. LED status is dimmed.

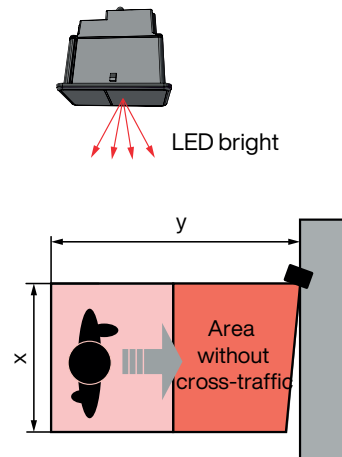

Figure 11: Person is detected entering detection area, moving towards the door entrance area. LED status is bright.

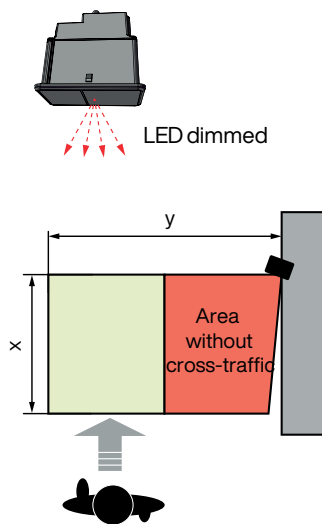

Figure 12: Detection field free; Person moves to cross the door entrance area. LED status is dimmed.

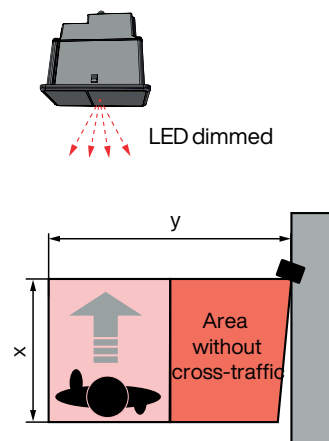
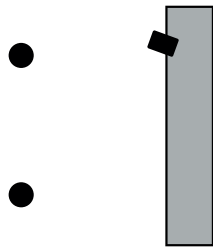
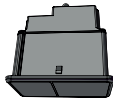

Figure 13: Sensor recognizes the person is moving cross the door entrance. LED status remains dimmed à no output switched.

# 10. Blanking

The TOF-2D-EA features a blanking function. The TOF-2D-EA triggers the output when objects are dynamic (moving) within the detection field. Static objects within the detection field will be ignored and blanked out (after 30 seconds). This covers with objects that are already present at power up (i.e. bollards).

## Start-up:



LED dimmed

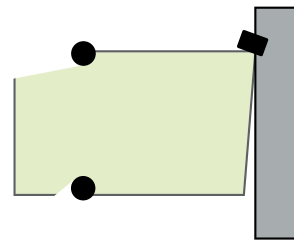
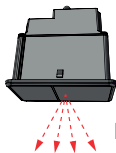

Figure 14: Active blanking - start-up sequence with i.e. bollards.

Figure 15: After start-up the bollards are blanked out from the detection field.

## Active blanking:



LED dimmed

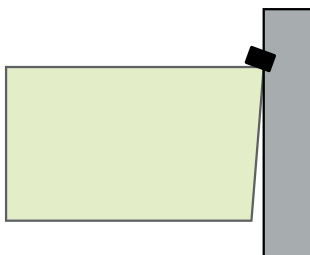
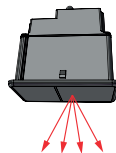

Figure 16: The detection field is free.



LED bright

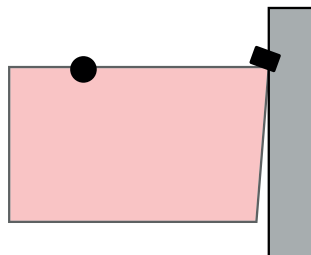

Figure 17: A static object is placed in the detection field (i.e. a trash bag). The object will be detected.



LED dimmed

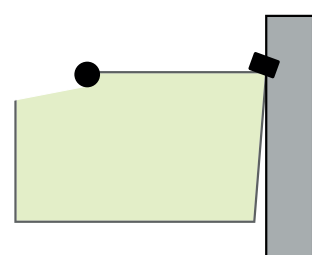

Figure 18: After 30 s the static object will be blanked out and the TOF-2D-EA continues its operation with the new geometry

# 11. Trouble shooting

Status	Action
LED off	<ul style="list-style-type: none"><li>■ Check supply power</li><li>■ Check electrical connections</li></ul>
Object in the safeguarded area and LED dimmed red	<ul style="list-style-type: none"><li>■ Check distance setting</li></ul>
No object in the safeguarded area and LED bright red	<ul style="list-style-type: none"><li>■ Check electrical connections</li><li>■ Check distance setting</li></ul>

If the problem persists, please contact Sensotek GmbH (+49 7163 93926-0; info@de.sensotek.com; www.sensotek.com).

# 12. Maintenance

Although the TOF-2D-EA does not need regular maintenance, a periodical functional check is strongly recommended as follows:

- Check the mounting position and detection area of the sensor.
- Clean the optical window with a soft towel and a little soapy water.



**Note: Damage to the optical window**

Never use any solvents, cleaners or mechanically abrasive towels or high pressure water to clean the sensors.

# 13. ESD-Safety



**Warning!** The device contains sensitive electronic components that may be affected by electrostatic discharge (ESD). Use appropriate ESD protection measures, such as wrist straps, to protect the device from damage.

# 14. Decommissioning



**Note:** The device may only be taken out of service by trained specialist personnel. Before dismantling, ensure that the power supply is disconnected.

## 15. Disposal



The TOF-2D-EA should only be replaced if a similar protection device is installed. Disposal should be done using the most up-to-date recycling technology according to local regulations and laws. There are no harmful materials used in the design and manufacture of the sensor. Traces of such dangerous materials may be found in the electronic components but not in the quantities that are harmful.